

REVISION HISTORY		
REV.	DESCRIPTION	DATE
A	INITIAL RELEASE	1996-05-22
B	UPDATED PER CR 841	2003-01-07
C	REVISE PER EC4270	2016-02-19

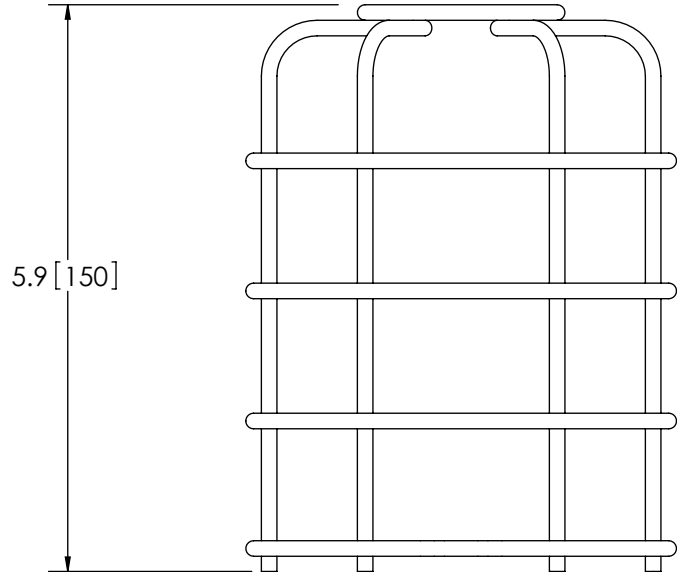
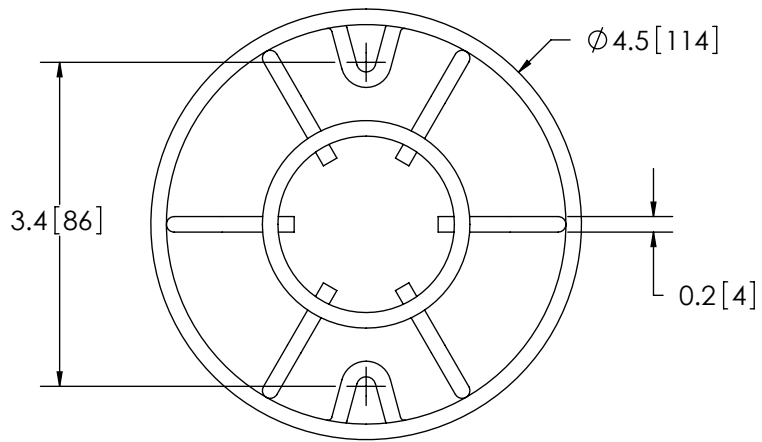

- NOTES:
1. MATERIAL: STEEL
  2. COLOR: BLACK
  3. WEIGHT: 0.6 LBS
  4. MOUNTING: USES EXISTING 62XX FASTENERS
  5. DIMENSIONS IN INCHES[MILLIMETERS (FOR REFERENCE)]

SCALE 1:2		APPROVALS	DATE																				
CAD GENERATED DRAWING FROM SOLID MODEL: REV. A DO NOT MANUALLY UPDATE.		DRAWN BY ABD	2016-02-18																				
TOLERANCES ARE IN INCHES, AND MILLIMETERS TOLERANCES UNLESS OTHERWISE STATED ARE:		CHECKED ABB	2016-02-19																				
<table border="1"> <thead> <tr> <th>MILLIMETERS DECIMALS</th> <th>INCHES DECIMALS</th> <th>ANGLES</th> <th>FRACTIONS</th> </tr> </thead> <tbody> <tr> <td>0-20 ± 0.5</td> <td>≥20-100 ± 0.2</td> <td>≥100-200 ± 1.0</td> <td>≥200 ± 2.0</td> </tr> <tr> <td>.XX ± 0.2</td> <td>.X ± 0.1</td> <td>.XXX ± .01</td> <td>± 0.5°</td> </tr> <tr> <td>.XX.X ± 0.3</td> <td>.XXX ± .005</td> <td>.XXXX ± .0030</td> <td>± 1/64</td> </tr> <tr> <td>.XX.XX ± 0.1</td> <td>.XXXX ± .0030</td> <td></td> <td></td> </tr> </tbody> </table>		MILLIMETERS DECIMALS	INCHES DECIMALS	ANGLES	FRACTIONS	0-20 ± 0.5	≥20-100 ± 0.2	≥100-200 ± 1.0	≥200 ± 2.0	.XX ± 0.2	.X ± 0.1	.XXX ± .01	± 0.5°	.XX.X ± 0.3	.XXX ± .005	.XXXX ± .0030	± 1/64	.XX.XX ± 0.1	.XXXX ± .0030			MECH. ENG. JLA	2016-02-18
MILLIMETERS DECIMALS	INCHES DECIMALS	ANGLES	FRACTIONS																				
0-20 ± 0.5	≥20-100 ± 0.2	≥100-200 ± 1.0	≥200 ± 2.0																				
.XX ± 0.2	.X ± 0.1	.XXX ± .01	± 0.5°																				
.XX.X ± 0.3	.XXX ± .005	.XXXX ± .0030	± 1/64																				
.XX.XX ± 0.1	.XXXX ± .0030																						
		ELEC. ENG.																					
		MFG. ENG. KLR	2016-02-18																				
		Test. ENG.																					
THIRD ANGLE PROJECTION		Electronically Controlled Use Latest Copy																					

United States  
1-800-635-5900  
Americas@eccogroup.com

United Kingdom  
+44 (0)113 237 5340  
Europe@eccogroup.com

Australia  
+61 (0)3 6332444  
AsiaPacific@eccogroup.com

**ACCESSORY BRANCH GUARD,6220**

NON DISCLOSURE AGREEMENT

THIS DRAWING AND THE DESIGN IT DISCLOSES ARE THE PRIVATE PROPERTY OF ESG AND IS ISSUED IN CONFIDENCE FOR ENGINEERING INFORMATION ONLY. THE DRAWING AND / OR DESIGN MAY NOT BE USED, COPIED, REPRODUCED, OR OTHERWISE DISCLOSED IN PART OR AS A WHOLE TO OUTSIDERS OR USED FOR ANY OTHER PURPOSE WITHOUT THE PRIOR WRITTEN CONSENT OF ESG. THE DRAWING IS SUBJECT TO RECALL AT ANY TIME. YOUR POSSESSION OF THIS DOCUMENT CONSTITUTES ACCEPTANCE OF THESE TERMS. © 2003 ECCO SAFETY GROUP.

SIZE: A	DWG. NO. A6220BG	REV. C
SHEET 1 OF 1	Project: CR 841	Date Created: 2003-01-07